

POWERPOINT® SLIDES TO ACCOMPANY
AUTOMOTIVE FUEL AND
EMISSIONS CONTROL SYSTEMS

SECOND EDITION

BY
JAMES D. HALDERMAN
AND
JIM LINDER

CHAPTER 4: DIESEL ENGINE OPERATION AND DIAGNOSIS

**PROFESSIONAL
TECHNICIAN**



**PEARSON
AUTOMOTIVE**

OBJECTIVES

After studying Chapter 4, the reader should be able to:

1. Prepare for ASE Engine Performance (A8) certification test content area “C” (Fuel, Air Induction, and Exhaust Systems Diagnosis and Repair).
2. Explain how a diesel engine works.
3. Describe the difference between direct injection (DI) and indirect injection (IDI) diesel engines.
4. List the parts of the typical diesel engine fuel system.
5. Explain how glow plugs work.
6. List the advantages and disadvantages of a diesel engine.
7. Describe how diesel fuel is rated and tested. Hydraulic Electronic

DIESEL ENGINES

- In 1892, a German engineer named Rudolf Diesel perfected the compression-ignition engine that bears his name.
- The diesel engine uses heat created by compression to ignite the fuel, so it requires no spark ignition system.

DIESEL ENGINES

- The diesel engine requires compression ratios of 16:1 and higher.
- Incoming air is compressed until its temperature reaches about 1,000° F (540° C).
- This is called **heat of compression**.
- As the piston reaches the top of its compression stroke, fuel is injected into the cylinder, where it is ignited by the hot air

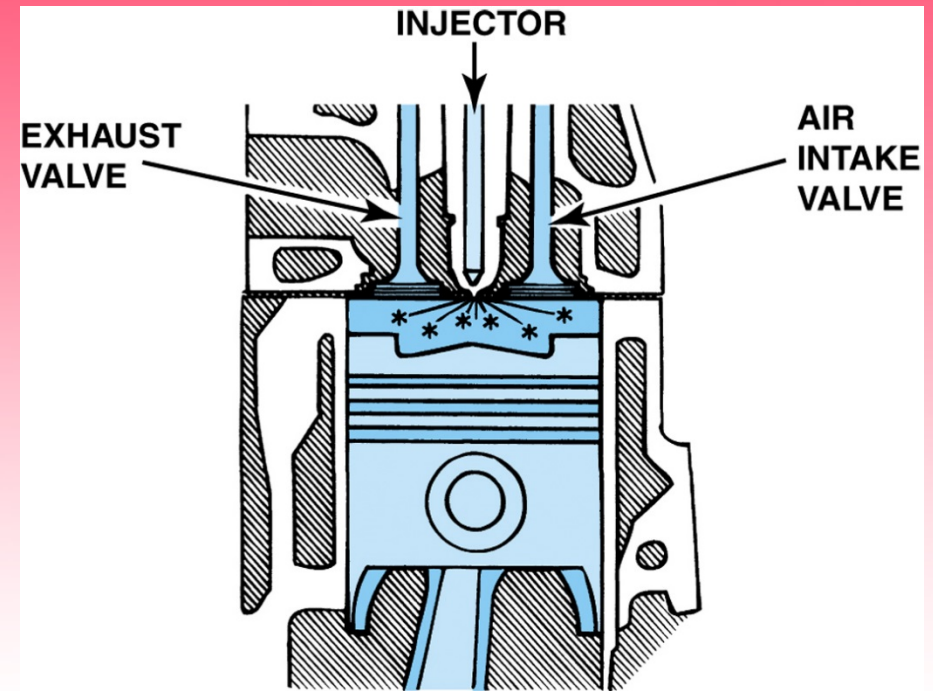

FIGURE 4-1 Diesel combustion occurs when fuel is injected into the hot, highly compressed air in the cylinder.

DIESEL ENGINES

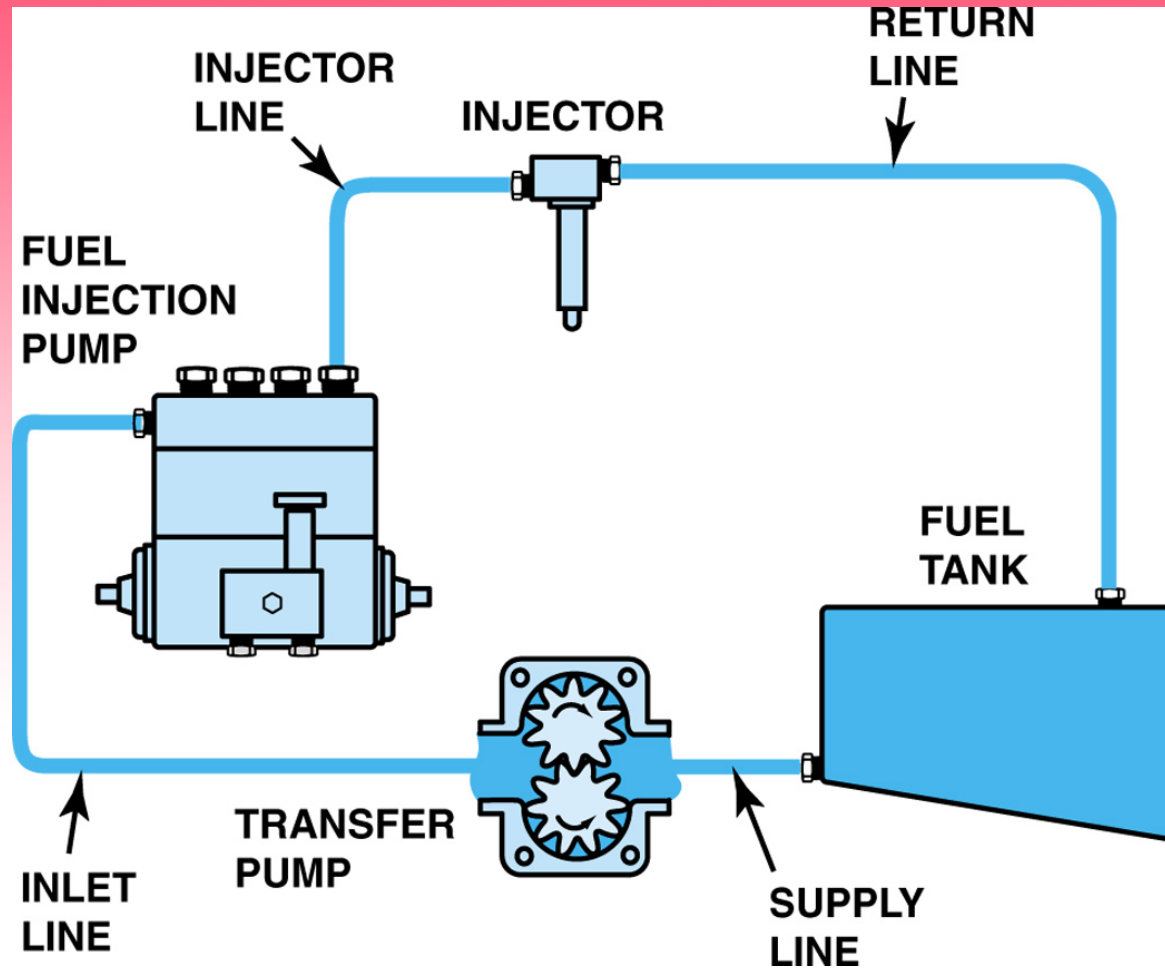

FIGURE 4-2 A typical injector-pump-type automotive diesel fuel injection system.

DIESEL ENGINES

Indirect and Direct Injection

- In an **indirect injection** (abbreviated **IDI**) diesel engine, fuel is injected into a small prechamber, which is connected to the cylinder by a narrow opening.
- The initial combustion takes place in this prechamber.
- This has the effect of slowing the rate of combustion, which tends to reduce noise.

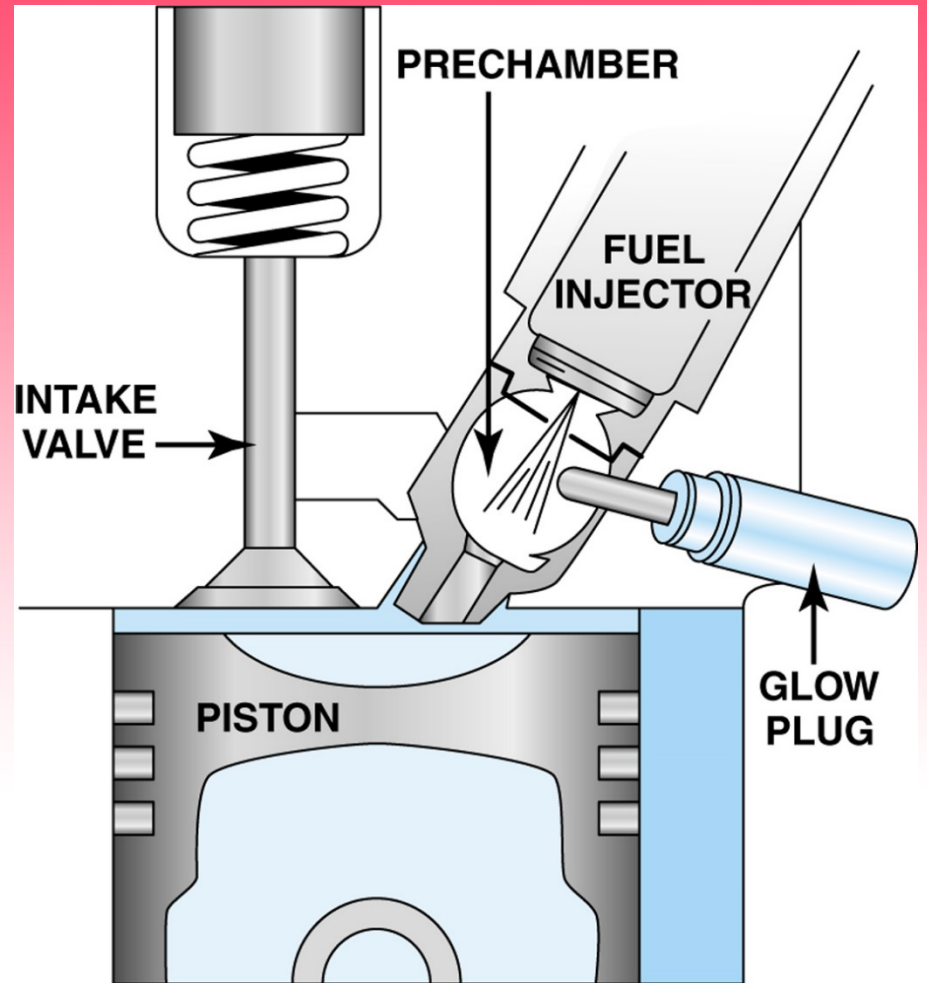

FIGURE 4-3 An indirect injection diesel engine uses a prechamber and a glow plug.

DIESEL ENGINES

Indirect and Direct Injection

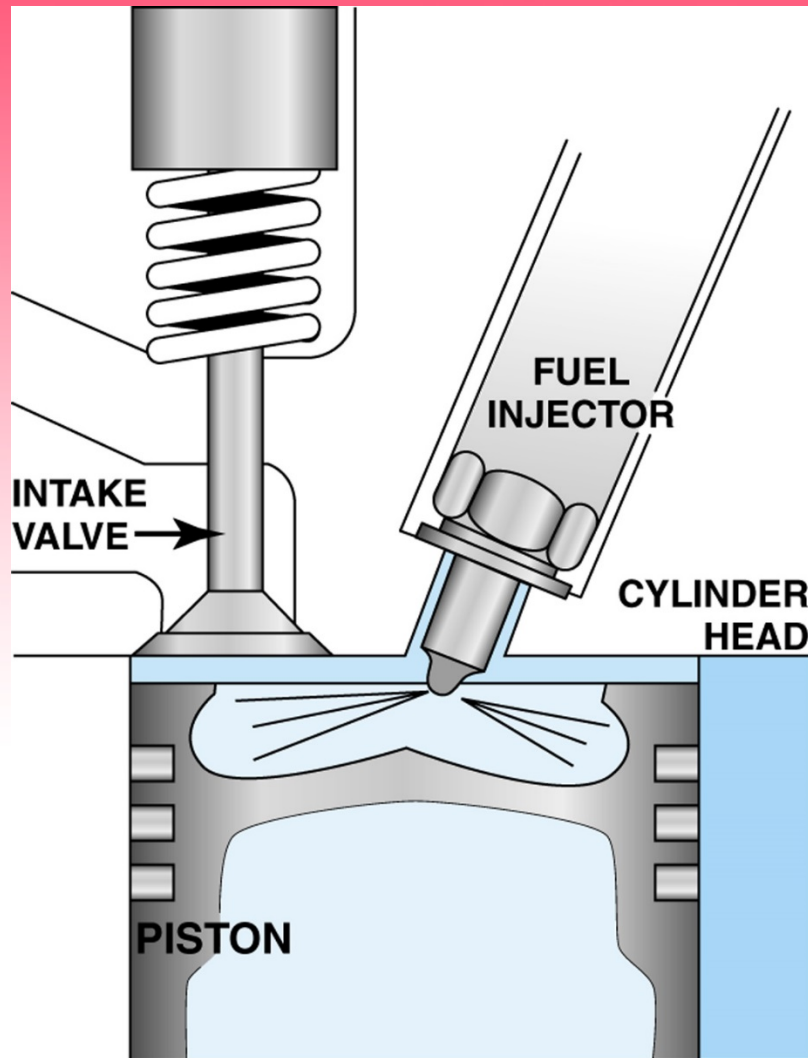

FIGURE 4-4 A direct injection diesel engine injects the fuel directly into the combustion chamber. Many designs do not use a glow plug.

DIESEL ENGINES

Diesel Fuel Ignition

- Ignition occurs in a diesel engine by injecting fuel into the air charge, which has been heated by compression to a temperature greater than the ignition point of the fuel or about 1,000° F (538° C).

THREE PHASES OF COMBUSTION

- There are three distinct phases or parts to the combustion in a diesel engine.
 - **Ignition delay.**
 - **Rapid combustion.**
 - **Controlled combustion.**

DIESEL ENGINE CONSTRUCTION

- Diesel engines must be constructed heavier than gasoline engines because of the tremendous pressures that are created in the cylinders during operation.
- The torque output of a diesel engine is often double or more than the same size gasoline powered engines.

DIESEL ENGINE CONSTRUCTION

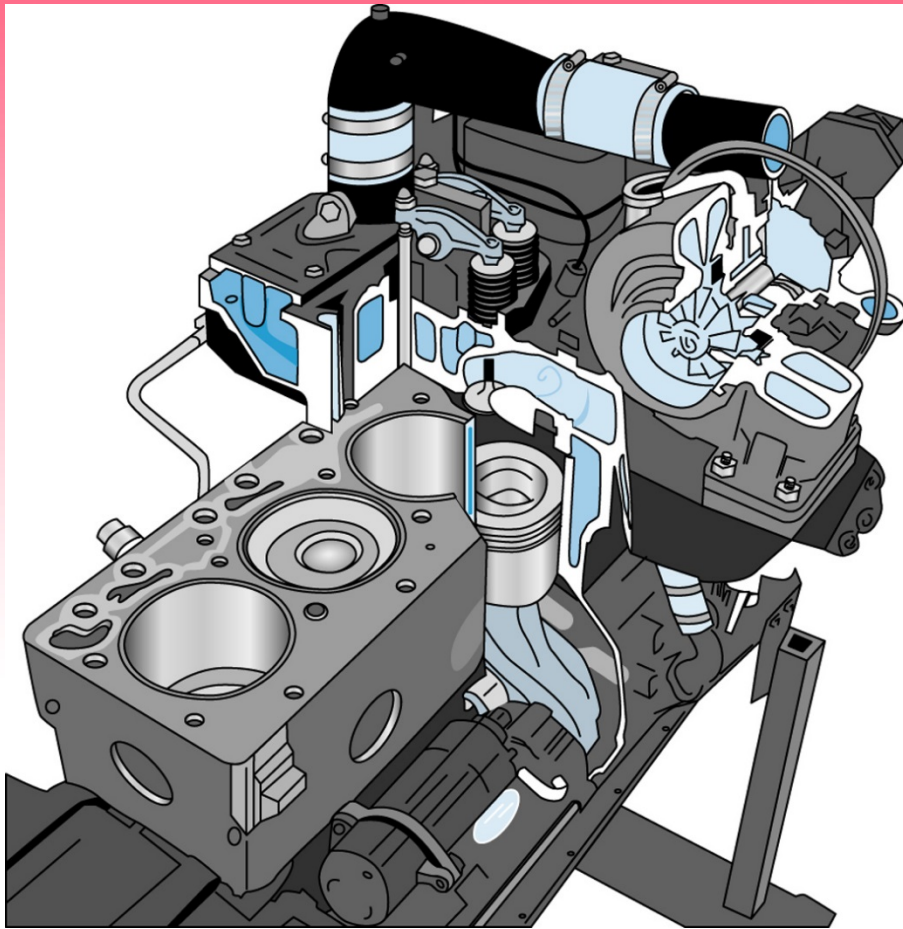

FIGURE 4-5 The common rail on a Cummins diesel engine. A highpressure pump (up to 30,000 PSI) is used to supply diesel fuel to this common rail, which has cubes running to each injector. Note the thick cylinder walls and heavy-duty construction.

DIESEL ENGINE CONSTRUCTION

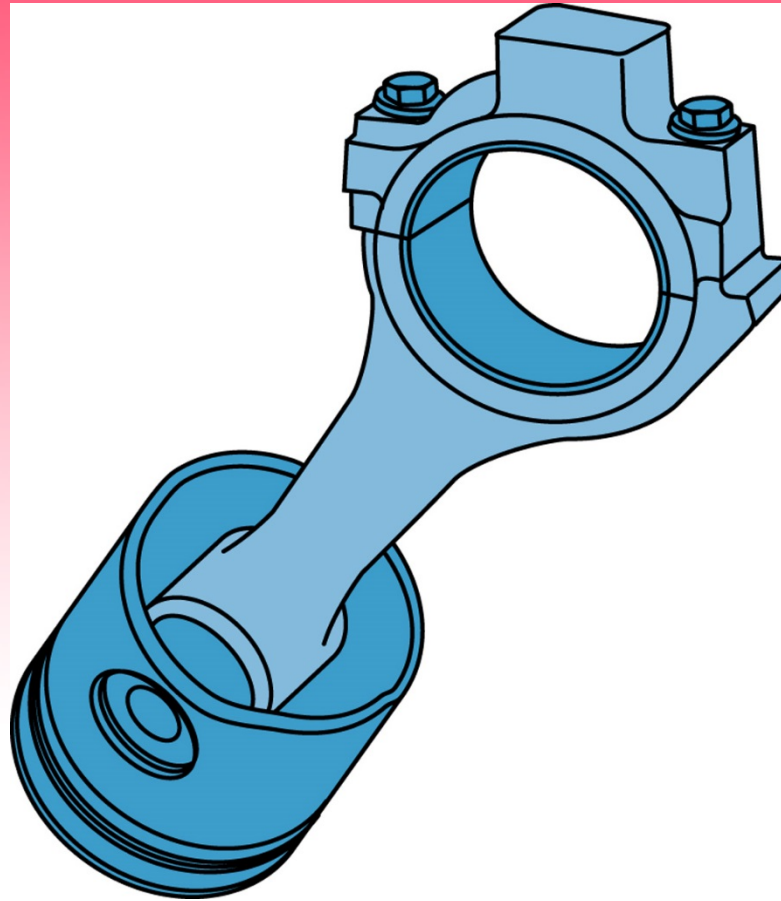

FIGURE 4-6 A rod/piston assembly from a 5.9-liter Cummins diesel engine used in a Dodge pickup truck.

FUEL TANK AND LIFT PUMP

- A fuel tank used on a vehicle equipped with a diesel engine differs from the one used with a gasoline engine in several ways, including:
 - A larger filler neck for diesel fuel.
 - No evaporative emission control devices or charcoal (carbon) canister.
- The diesel fuel is drawn from the fuel tank by a **lift pump** and delivers the fuel to the injection pump.
- Between the fuel tank and the lift pump is a **water-fuel separator**.
 - Water is heavier than diesel fuel and sinks to the bottom of the separator.

FUEL TANK AND LIFT PUMP

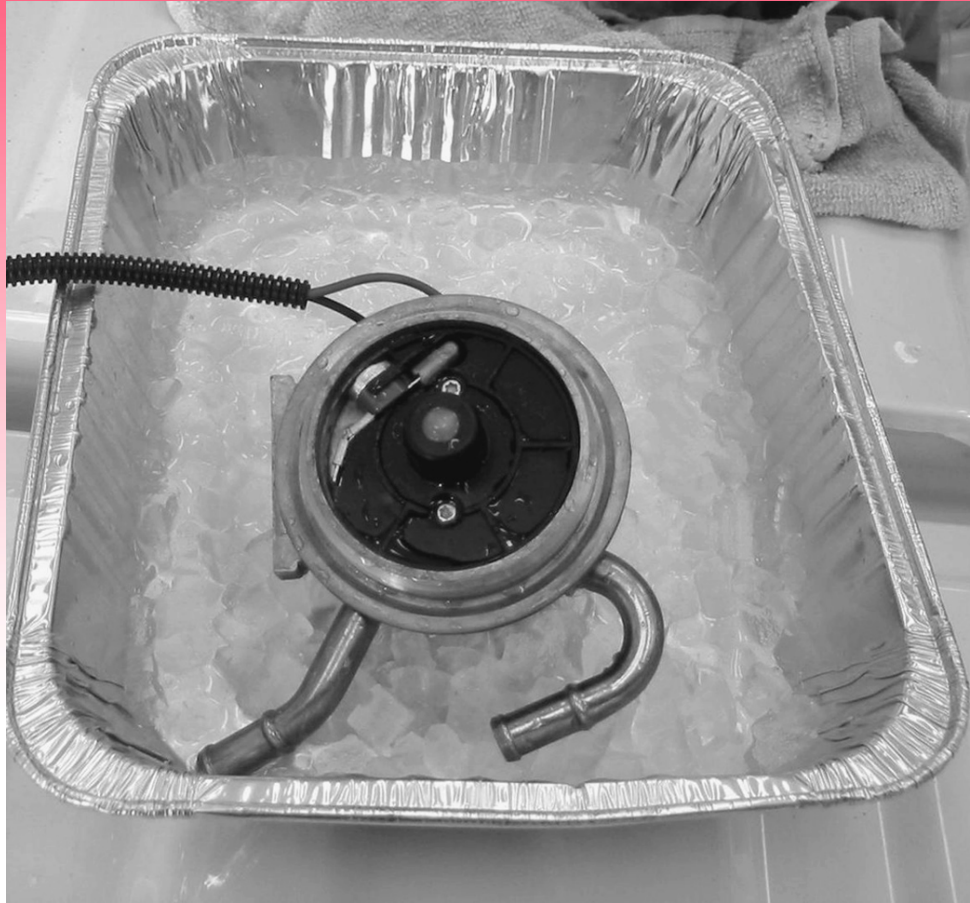

FIGURE 4-7 Using an ice bath to test the fuel temperature sensor.

DIESEL ENGINE FUEL SYSTEM

Injection Pump

- A diesel engine injection pump is used to increase the pressure of the diesel fuel from very low values from the lift pump to the extremely high pressures needed for injection.

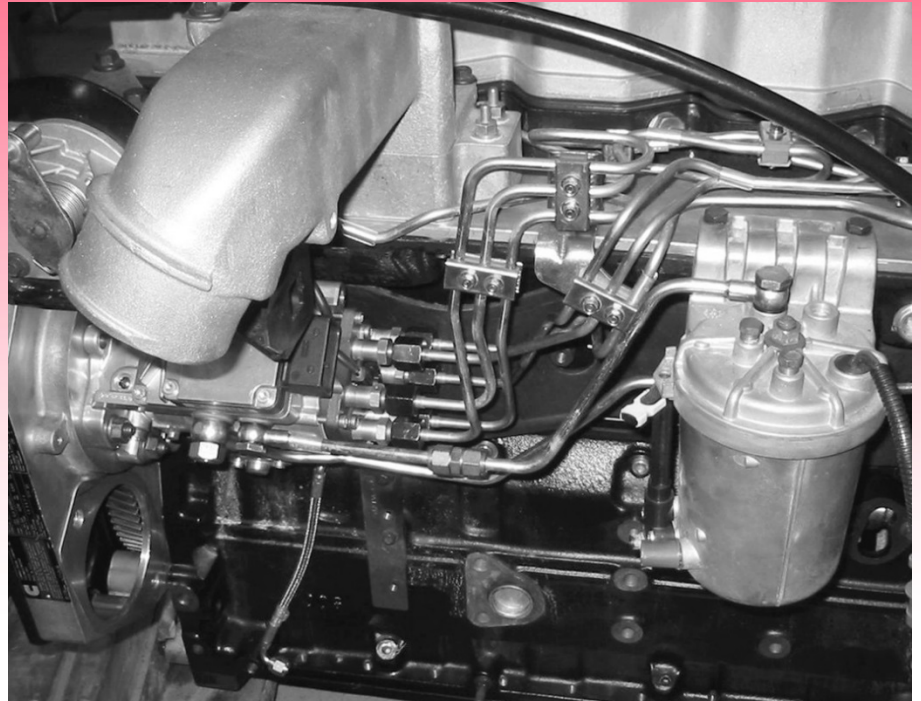

FIGURE 4-8 A typical distributor-type diesel injection pump showing the pump, lines, and fuel filter.

DIESEL ENGINE FUEL SYSTEM

Distributor Injection Pump

- A distributor diesel injection pump is a high-pressure pump assembly with lines leading to each individual injector.
- The high-pressure lines between the distributor and the injectors must be the exact same length to ensure proper injection timing.

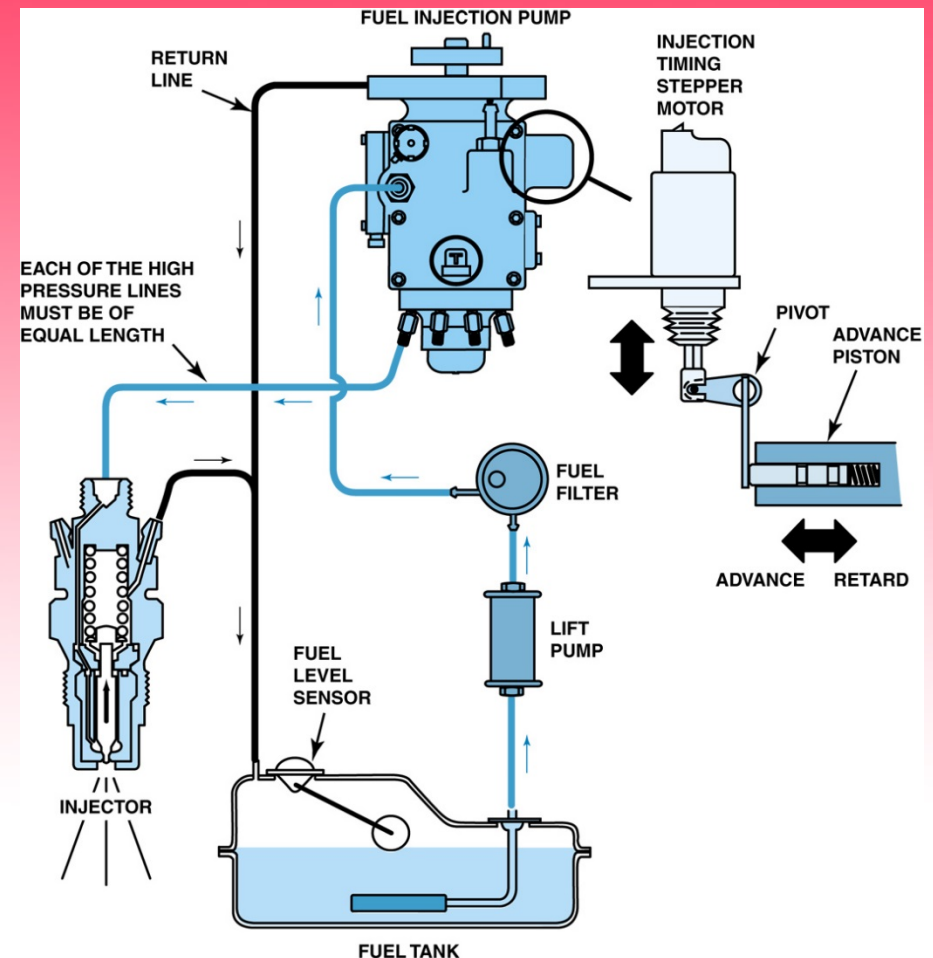

FIGURE 4-9 A schematic of a Stanadyne diesel fuel injection pump assembly showing all of the related components.

DIESEL ENGINE FUEL SYSTEM

High-Pressure Common Rail

- Newer diesel engines use a fuel delivery system referred to as a **high-pressure common rail (HPCR)** design.
 - Diesel fuel under high pressure, over 20,000 PSI (138,000 kPa), is applied to the injectors, which are opened by a solenoid controlled by the computer.

DIESEL ENGINE FUEL SYSTEM

High-Pressure Common Rail

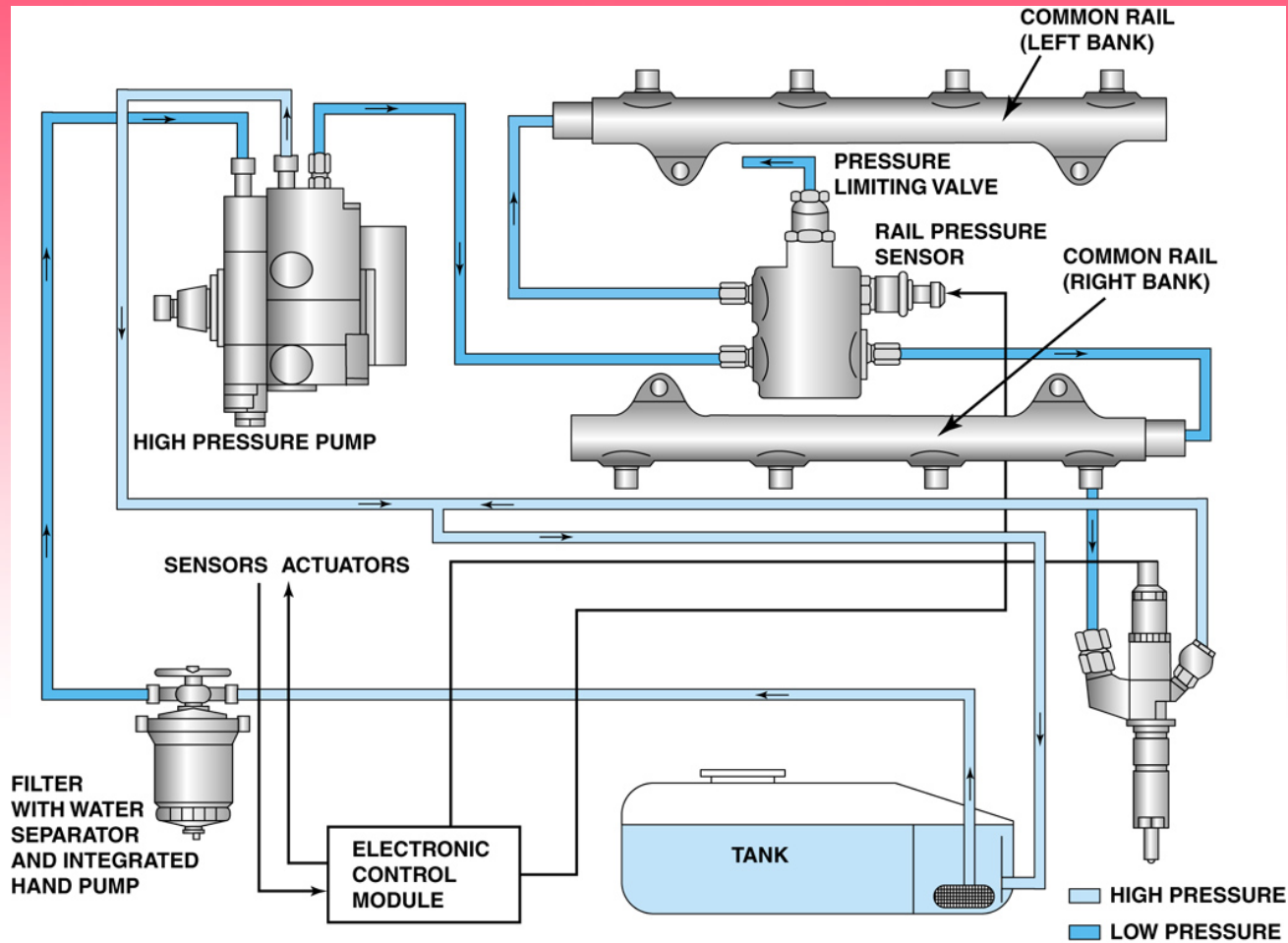

FIGURE 4-10 Overview of a computer-controlled high-pressure common rail V-8 diesel engine.

DIESEL ENGINE FUEL SYSTEM

HEUI System

- Ford 7.3- and 6.0-liter diesels use a system Ford calls a **Hydraulic Electronic Unit Injection** system, or **HEUI** system.
 - The components that replace the traditional mechanical injection pump include a high-pressure oil pump and reservoir, pressure regulator for the oil, and passages in the cylinder head for flow of fuel to the injectors.

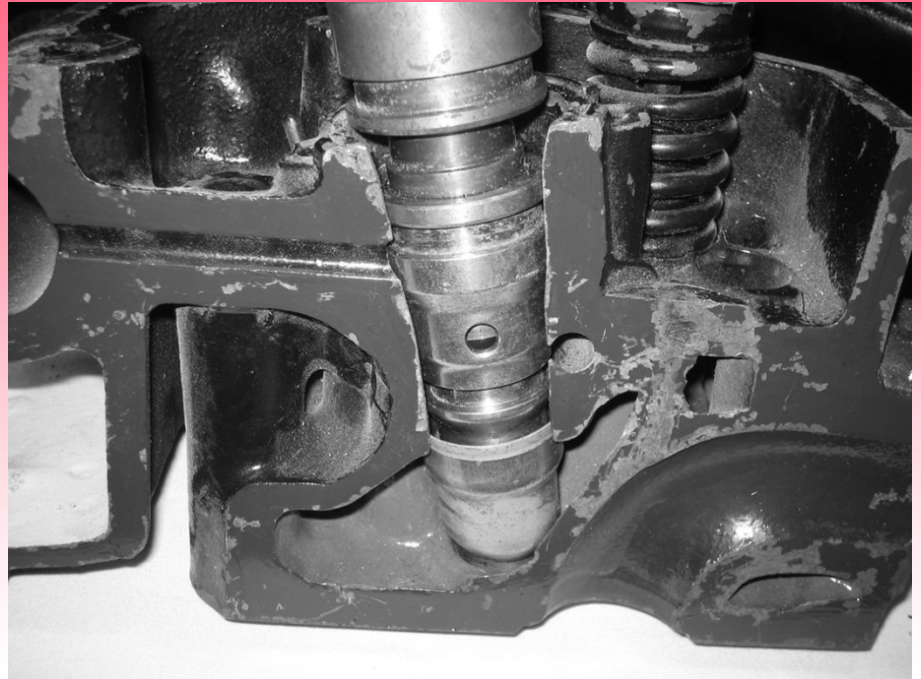

FIGURE 4-11 A HEUI injector from a Ford PowerStroke diesel engine. The grooves indicate the location of the O-rings.

DIESEL INJECTOR NOZZLES

- Diesel injector nozzles are spring-loaded closed valves that spray fuel directly into the combustion chamber or precombustion chamber.
- Injector nozzles are threaded into the cylinder head, one for each cylinder, and are replaceable as an assembly.
- The top of the injector nozzle has many holes to deliver an atomized spray of diesel fuel into the cylinder.
- Parts of a diesel injector nozzle include:
 - **Heat shield.**
 - **Injector body.**
 - **Diesel injector needle valve.**
 - **Injector pressure chamber.**

DIESEL INJECTOR NOZZLE OPERATION

- The electric solenoid attached to the injector nozzle is computer controlled and opens to allow fuel to flow into the injector pressure chamber.



FIGURE 4-12 Typical computer-controlled diesel engine fuel injectors.

GLOW PLUGS

- Glow plugs are always used in diesel engines equipped with a precombustion chamber and may be used in direct injection diesel engines to aid starting.
- A **glow plug** is a heating element that uses 12 volts from the battery and aids in the starting of a cold engine.
- As the temperature of the glow plug increases, the resistance of the heating element inside increases, thereby reducing the current in amperes needed by the glow plugs.

GLOW PLUGS

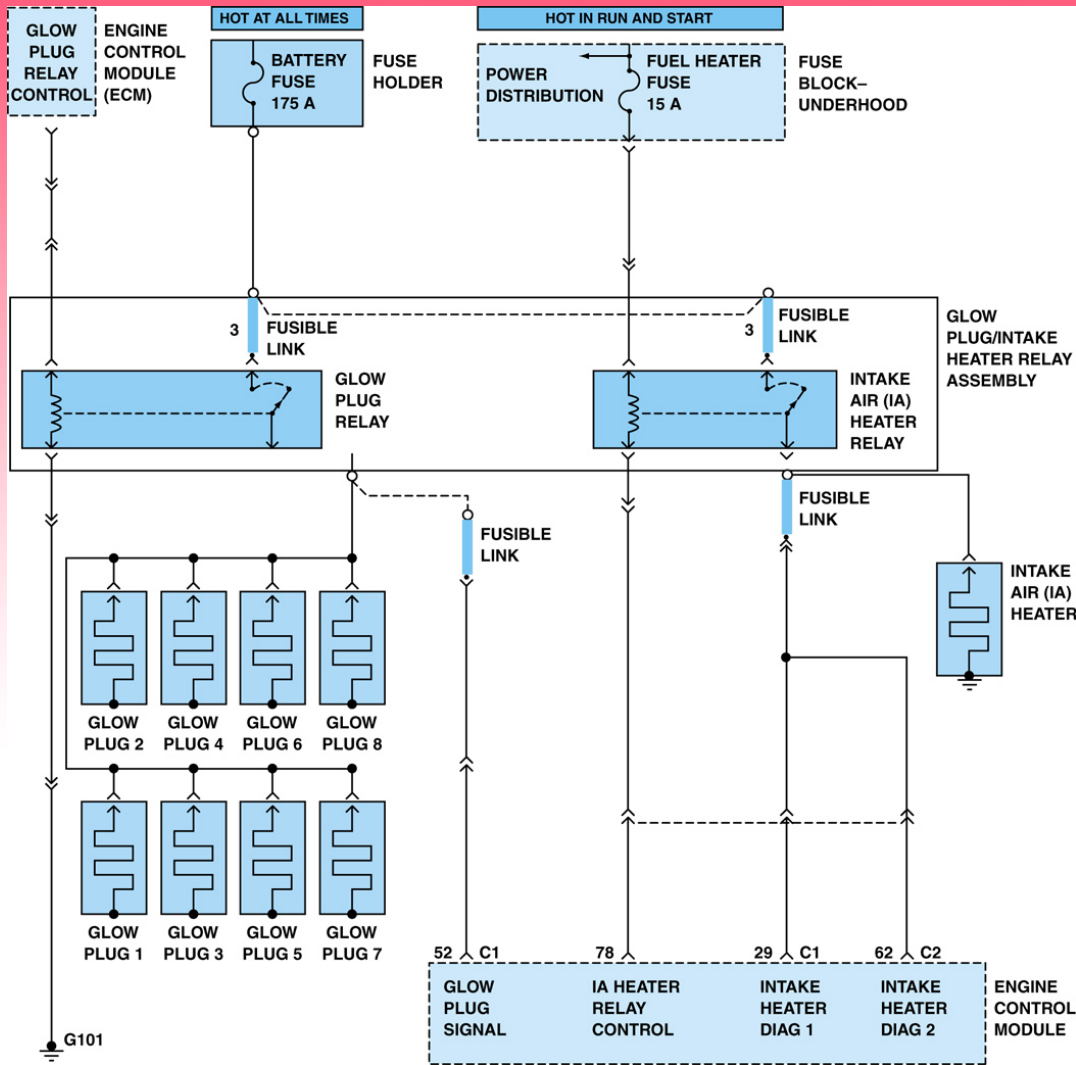

FIGURE 4-13 A schematic of a typical glow plug circuit. Notice that the relay for the glow plug and intake air heater are both computer controlled.

ENGINE-DRIVEN VACUUM PUMP

- Because a diesel engine is unthrottled, it creates very little vacuum in the intake manifold.
- Several engine and vehicle components operate using vacuum, such as the exhaust gas recirculation (EGR) valve and the heating and ventilation blend and air doors.
- Most diesels used in cars and light trucks are equipped with an engine-driven vacuum pump to supply the vacuum for these components.

WHAT ARE DIESEL ENGINE ADVANTAGES AND DISADVANTAGES?



FIGURE 4-14 Roller lifter from a GM Duramax 6.6-liter V-8 diesel engine. Notice the size of this lifter compared to a roller lifter used in a gasoline engine.

DIESEL FUEL

- Diesel fuel must meet an entirely different set of standards than gasoline.
- The fuel in a diesel engine is not ignited with a spark, but is ignited by the heat generated by high compression.
- All diesel fuel must be clean, be able to flow at low temperatures, and be of the proper cetane rating.
 - **Cleanliness.**
 - **Low-temperature fluidity.**
 - **Cetane number.**

DIESEL FUEL SPECIFIC GRAVITY TESTING

- The density of diesel fuel should be tested whenever there is a driveability concern.
- The density or specific gravity of diesel fuel is measured in units of **API gravity**.
- API gravity is an arbitrary scale expressing the gravity or density of liquid petroleum products devised jointly by the American Petroleum Institute and the National Bureau of Standards.

DIESEL FUEL SPECIFIC GRAVITY TESTING



FIGURE 4-15 A
hydrometer is used to measure the API specific gravity of diesel fuel. The unit of measure is usually the American Petroleum Institute (API) scale.

DIESEL FUEL HEATERS

- Diesel fuel heaters help prevent power loss and stalling in cold weather.
- The heater is placed in the fuel line between the tank and the primary filter.
- Some coolant heaters are thermostatically controlled, which allows fuel to bypass the heater once it has reached operating temperature.

HEATED INTAKE AIR

- Some diesels, such as the General Motors 6.6-liter Duramax V-8, use an electrical heater wire to warm the intake air to help in cold weather starting and running.



FIGURE 4-16 A wire wound electrical heater is used to warm the intake air on some diesel engines.

ACCELERATOR PEDAL POSITION SENSOR

- Some light truck diesel engines are equipped with an electronic throttle to control the amount of fuel injected into the engine.
- Because a diesel engine does not use a throttle in the air intake, the only way to control engine speed is by controlling the amount of fuel being injected into the cylinders.
- Instead of a mechanical link from the accelerator pedal to the diesel injection pump, a throttle-by-wire system uses an accelerator pedal position sensor.
- To ensure safety, it consists of three separate sensors that change in voltage as the accelerator pedal is depressed.

ACCELERATOR PEDAL POSITION SENSOR

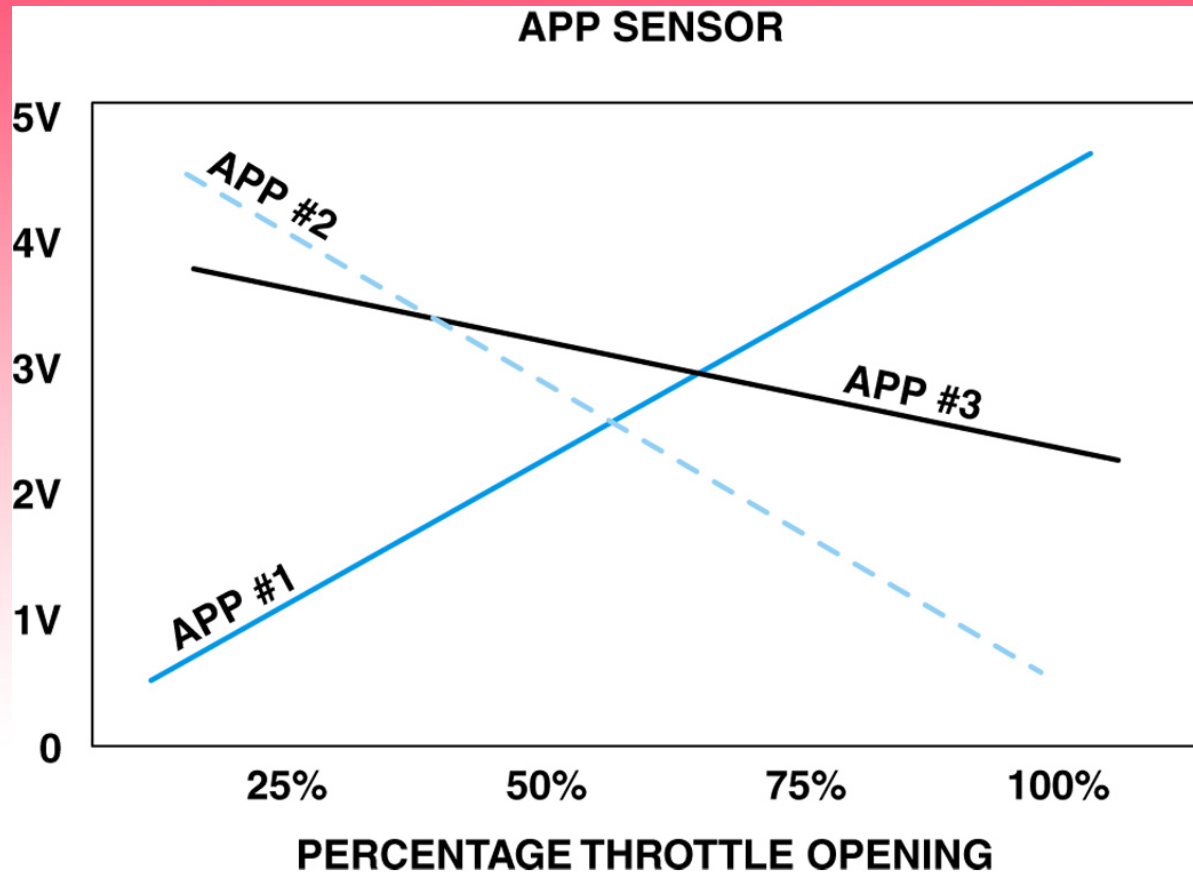

FIGURE 4-17 A typical accelerator pedal position (APP) sensor uses three different sensors in one package with each creating a different voltage as the accelerator is moved.

SOOT OR PARTICULATE MATTER

- Soot particles may come directly from the exhaust tailpipe or they can also form when emissions of nitrogen oxide and various sulfur oxides chemically react with other pollutants suspended in the atmosphere.
- Particulates are generally categorized as follows:
 - **TSP, Total Suspended Particulate.**
 - **PM10.**
 - **PM2.5.**

DIESEL OXIDATION CATALYST (DOC)

- **Diesel oxidation catalyst (DOC)** consists of a flow-through honeycomb-style substrate structure that is washcoated with a layer of catalyst materials, similar to those used in a gasoline engine catalytic converter.

DIESEL EXHAUST PARTICULATE FILTER (DPF)

- The heated exhaust gas from the DOC flows into the diesel particulate filter (DPF), which captures diesel exhaust gas particulates (soot) to prevent them from being released into the atmosphere.
- This is done by forcing the exhaust through a porous cell which has a silicon carbide substrate with honeycombcell-type channels that trap the soot.

DIESEL EXHAUST PARTICULATE FILTER (DPF)



FIGURE 4-18 A diesel exhaust particulate filter on a Cummins 6.7-liter diesel engine.

DIESEL EXHAUST PARTICULATE FILTER (DPF)

- **Exhaust Gas Temperature Sensors**
- **DPF Differential Pressure Sensor (DPS)**
- **Diesel Particulate Filter Regeneration**
- **DPF Regeneration Process**
- **Types of DPF Regeneration**
 - **Passive Regeneration.**
 - **Active Regeneration.**
- **DPF Service Regeneration**
- **Conditions for Running a DPF Service Regeneration**

DIESEL EXHAUST PARTICULATE FILTER (DPF)



FIGURE 4-19 A differential pressure sensor showing the two hoses from the diesel exhaust particulate filter.

ASH LOADING

- Regeneration will not burn off ash.
- Only the particulate matter (PM) is burned off during regeneration.
- Ash is a noncombustible by-product from normal oil consumption.
- Ash accumulation in the DPF will eventually cause a restriction in the particulate filter.
- To service an ash loaded DPF, the DPF will need to be removed from the vehicle and cleaned or replaced.

DIESEL EXHAUST SMOKE DIAGNOSIS

- **Black Smoke**
- **White Smoke**
- **Gray or Blue Smoke**

SCAN TOOL DIAGNOSIS

- All light truck diesels since 1996 have also adhered to on-board diagnostic systems (second generation [OBD-II]).
- The use of a scan tool to check for diagnostic trouble codes (DTCs) and to monitor engine operation is one of the first diagnostic steps.



FIGURE 4-20 A scan tool is used to retrieve diagnostic trouble codes and to perform injector balance tests.

COMPRESSION TESTING

- A compression test is fundamental for determining the mechanical condition of a diesel engine.
- Worn piston rings can cause low power and excessive exhaust smoke.

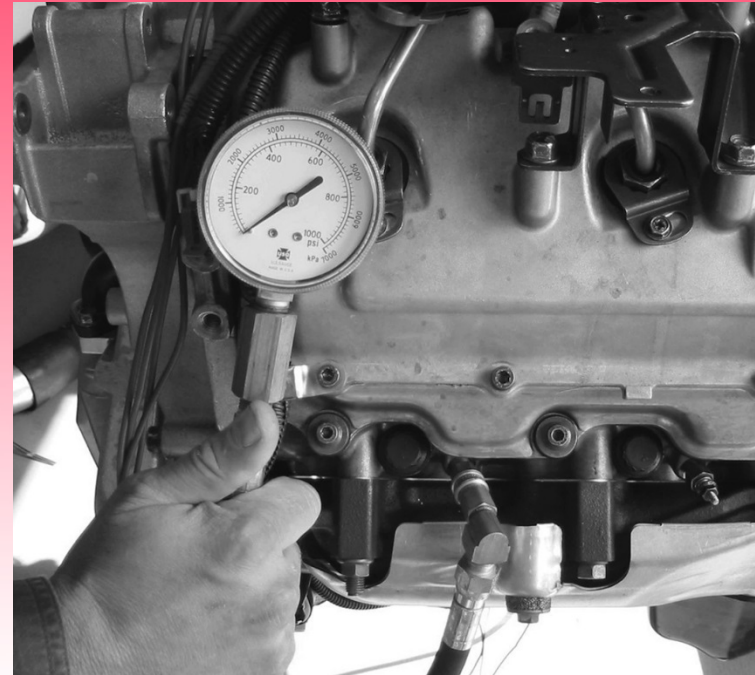

FIGURE 4-21 A compression gauge designed for the higher compression rate of a diesel engine should be used when checking the compression. In most newer diesel engines the glow plug is removed and the compression tester is threaded into the glow plug hole to measure the compression.

GLOW PLUG RESISTANCE BALANCE TEST

- Glow plugs increase in resistance as their temperature increases.
- All glow plugs should have about the same resistance when checked with an ohmmeter.
- A similar test of the resistance of the glow plugs can be used to detect a weak cylinder.

INJECTOR POP TESTING

- A **pop tester** is a device used for checking a diesel injector nozzle for proper spray pattern.
- The handle is depressed and pop off pressure is displayed on the gauge.

FIGURE 4-22 A typical pop tester used to check the spray pattern of a diesel engine injector.

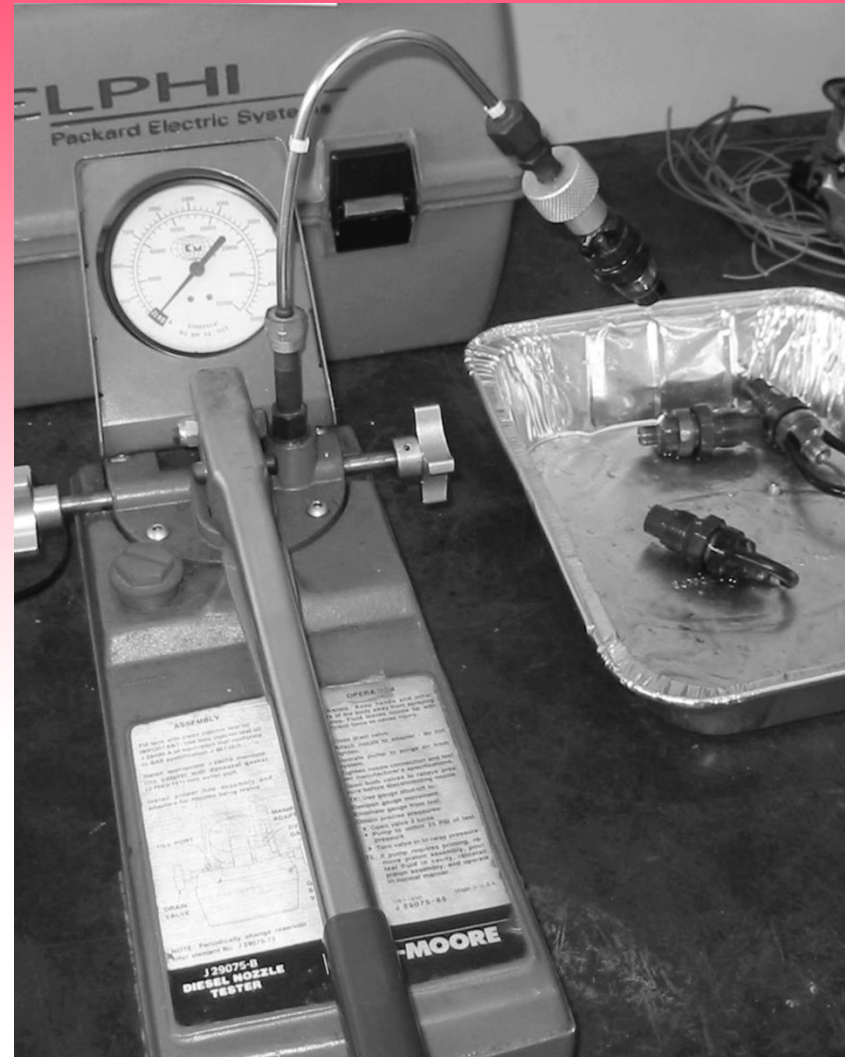

DIESEL EMISSION TESTING

- The most commonly used diesel exhaust emission test used in state or local testing programs is called the **opacity** test.
- Opacity means the percentage of light that is blocked by the exhaust smoke.
 - A 0% opacity means that the exhaust has no visible smoke and does not block light from a beam projected through the exhaust smoke.
 - A 100% opacity means that the exhaust is so dark that it completely blocks light from a beam projected through the exhaust smoke.
 - A 50% opacity means that the exhaust blocks half of the light from a beam projected through the exhaust smoke.

DO NOT SWITCH INJECTORS



FIGURE 4-23 The letters on the side of this injector on a Cummins 6.7-liter diesel indicate the calibration number for the injector.

DIESEL EMISSION TESTING

- **Snap Acceleration Test**
- **Rolling Acceleration Test**
- **Stall Acceleration Test**

SUMMARY

1. A diesel engine uses heat of compression to ignite the diesel fuel when it is injected into the compressed air in the combustion chamber.
2. There are two basic designs of combustion chambers used in diesel engines. Indirect injection (IDI) uses a precombustion chamber whereas a direct injection (DI) occurs directly into the combustion chamber.
3. The three phases of diesel combustion include:
 - a. Ignition delay
 - b. Rapid combustion
 - c. Controlled combustion

SUMMARY

4. The typical diesel engine fuel system consists of the fuel tank, lift pump, water-fuel separator, and fuel filter.
5. The engine-driven injection pump supplies high-pressure diesel fuel to the injectors.
6. The two most common types of fuel injection used in automotive diesel engines are:
 - a. Distributor-type injection pump
 - b. Common rail design where all of the injectors are fed from the same fuel supply from a rail under high pressure
7. Injector nozzles are either opened by the high-pressure pulse from the distributor pump or electrically by the computer on a common rail design.

SUMMARY

8. Glow plugs are used to help start a cold diesel engine and help prevent excessive white smoke during warm-up.
9. The higher the cetane rating of diesel fuel, the more easily the fuel is ignited.
10. Most automotive diesel engines are designed to operate on grade #2 diesel fuel in moderate weather conditions.
11. The API specific gravity of diesel fuel should be 30 to 39 with a typical reading of 35 for #2 diesel fuel.
12. Diesel engines can be tested using a scan tool, as well as measuring the glow plug resistance or compression reading to determine a weak or nonfunctioning cylinder.

REVIEW QUESTIONS

1. What is the difference between direct injection and indirect injection?
2. What are the three phases of diesel ignition?
3. What are the three most commonly used types of automotive diesel injection systems?
4. Why are glow plugs kept working after the engine starts?
5. What is the advantage of using diesel fuel with a high cetane rating?
6. How is the specific gravity of diesel fuel tested?

CHAPTER QUIZ

1. How is diesel fuel ignited in a warm diesel engine?
 - a) Glow plugs
 - b) Heat of compression
 - c) Spark plugs
 - d) Distributorless ignition system

CHAPTER QUIZ

1. How is diesel fuel ignited in a warm diesel engine?
 - a) Glow plugs
 - b) Heat of compression**
 - c) Spark plugs
 - d) Distributorless ignition system

CHAPTER QUIZ

2. Which type of diesel injection produces less noise?
- a) Indirect injection (IDI)
 - b) Common rail
 - c) Direct injection
 - d) Distributor injection

CHAPTER QUIZ

2. Which type of diesel injection produces less noise?
- a) **Indirect injection (IDI)**
 - b) Common rail
 - c) Direct injection
 - d) Distributor injection

CHAPTER QUIZ

3. Which diesel injection system requires the use of a glow plug?
- a) Indirect injection (IDI)
 - b) High-pressure common rail
 - c) Direct injection
 - d) Distributor injection

CHAPTER QUIZ

3. Which diesel injection system requires the use of a glow plug?
- a) **Indirect injection (IDI)**
 - b) High-pressure common rail
 - c) Direct injection
 - d) Distributor injection

CHAPTER QUIZ

4. The three phases of diesel ignition include _____.
- a) Glow plug ignition, fast burn, slow burn
 - b) Slow burn, fast burn, slow burn
 - c) Ignition delay, rapid combustion, controlled combustion
 - d) Glow plug ignition, ignition delay, controlled combustion

CHAPTER QUIZ

4. The three phases of diesel ignition include _____.
- a) Glow plug ignition, fast burn, slow burn
 - b) Slow burn, fast burn, slow burn
 - c) Ignition delay, rapid combustion, controlled combustion
 - d) **Glow plug ignition, ignition delay, controlled combustion**

CHAPTER QUIZ

5. What fuel system component is used in a vehicle equipped with a diesel engine that is not usually used on the same vehicle when it is equipped with a gasoline engine?
- a) Fuel filter
 - b) Fuel supply line
 - c) Fuel return line
 - d) Water-fuel separator

CHAPTER QUIZ

5. What fuel system component is used in a vehicle equipped with a diesel engine that is not usually used on the same vehicle when it is equipped with a gasoline engine?
- a) Fuel filter
 - b) Fuel supply line
 - c) Fuel return line
 - d) Water-fuel separator**

CHAPTER QUIZ

6. The diesel injection pump is usually driven by a _____.
- a) Gear off the camshaft
 - b) Belt off the crankshaft
 - c) Shaft drive off of the crankshaft
 - d) Chain drive off of the camshaft

CHAPTER QUIZ

6. The diesel injection pump is usually driven by a _____.
- a) **Gear off the camshaft**
 - b) Belt off the crankshaft
 - c) Shaft drive off of the crankshaft
 - d) Chain drive off of the camshaft

CHAPTER QUIZ

7. Which diesel system supplies high-pressure diesel fuel to all of the injectors all of the time?
- a) Distributor
 - b) Inline
 - c) High-pressure common rail
 - d) Rotary

CHAPTER QUIZ

7. Which diesel system supplies high-pressure diesel fuel to all of the injectors all of the time?
- a) Distributor
 - b) Inline
 - c) High-pressure common rail**
 - d) Rotary

CHAPTER QUIZ

8. Glow plugs should have high resistance when _____ and lower resistance when _____.
- a) Cold/warm
 - b) Warm/cold
 - c) Wet/dry
 - d) Dry/wet

CHAPTER QUIZ

8. Glow plugs should have high resistance when _____ and lower resistance when _____.
- a) Cold/warm
 - b) Warm/cold**
 - c) Wet/dry
 - d) Dry/wet

CHAPTER QUIZ

9. Technician A says that glow plugs are used to help start a diesel engine and are shut off as soon as the engine starts. Technician B says that the glow plugs are turned off as soon as a flame is detected in the combustion chamber. Which technician is correct?
- a) Technician A only
 - b) Technician B only
 - c) Both Technicians A and B
 - d) Neither Technician A nor B

CHAPTER QUIZ

9. Technician A says that glow plugs are used to help start a diesel engine and are shut off as soon as the engine starts. Technician B says that the glow plugs are turned off as soon as a flame is detected in the combustion chamber. Which technician is correct?
- a) Technician A only
 - b) Technician B only
 - c) Both Technicians A and B
 - d) Neither Technician A nor B**

CHAPTER QUIZ

10. What part should be removed to test cylinder compression on a diesel engine?

- a) An injector
- b) An intake valve rocker arm and stud
- c) An exhaust valve
- d) A glow plug

CHAPTER QUIZ

10. What part should be removed to test cylinder compression on a diesel engine?

- a) An injector
- b) An intake valve rocker arm and stud
- c) An exhaust valve
- d) A glow plug**